

## Cisco Compatible QSFP-100G-SR1.2-FL Quick Spec:

Part Number:	QSFP28-100GBase-SR1.2 QSFP28-100GBase-SR1.2-EXT QSFP28-100GBase-SR1.2-IND
Form Factor:	QSFP28
TX Wavelength:	850nm/910nm
Reach:	100m
Cable Type:	OM4 MMF
Rate Category:	100GBase
Interface Type:	SR1.2
DDM:	Yes
Connector Type:	Dual-LC



## Cisco Compatible QSFP-100G-SR1.2-FL Features:

- 4 independent full-duplex channels
- Up to 28Gbps data rate per channel
- QSFP28 MSA compliant
- Up to 100m over OM4 MMF transmission
- Up to 70m over OM3 MMF transmission
- Single 3.3V power supply
- Maximum power consumption 3.5W
- MTP/MPO optical connector
- RoHS-6 compliant
- Operating Case Temperature
  - Standard: 0°C to +70 °C
  - Extended -5°C to +85 °C
  - Industrial -40°C to +85 °C

## Cisco Compatible QSFP-100G-SR1.2-FL Applications:

- Data Center, Rack to rack
- Infiniband HDR
- 100G Ethernet

## Cisco Compatible QSFP-100G-SR1.2-FL General Description

This product can support 100Gb/s bit rates. It is a parallel Quad Small Form-factor Pluggable (QSFP28) Bi-Direction optical module. The module integrates four host electrical data into two optical lanes (by Dual Wavelength VCSEL Bi-Directional Optical Interface, 850nm and 910nm) to allow optical communication over a 2-fiber duplex LC optical multi-mode fiber. Reversely, on the receiver side, the module de-multiplexes 2 sets of optical input signal and converts them to 4 channels of electrical data.

An optical fiber ribbon cable with an LC connector can be plugged into the QSFP28 module receptacle. Proper alignment is ensured by the guide pins inside the receptacle. The cable usually cannot be twisted for proper channel to channel alignment. Electrical connection is achieved through an MSA-compliant 38-pin edge type connector.

The module operates by a single +3.3V power supply. LVCMOS/LVTTL global control signals, such as Module Present, Reset, Interrupt and Low Power Mode, are available with the modules. A 2-wire serial interface is available to send and receive more complex control signals, and to receive digital diagnostic information. Individual channels can be addressed and unused channels can be shut down for maximum design flexibility.

The product is designed with form factor, optical/electrical connections, and digital diagnostic interface according to the QSFP28 Multi-Source Agreement (MSA). It has been designed to meet the harshest external operating conditions including temperature, humidity, and EMI interference. The module offers very high functionality and feature integration, accessible via a two-wire serial interface.

## Functional Description

This product can support 100Gb/s bit rates. It is a parallel Quad Small Form-factor Pluggable (QSFP28) Bi-Direction optical module. The module integrates four host electrical data into two optical lanes (by Dual Wavelength VCSEL Bi-Directional Optical Interface, 850nm and 900nm) to allow optical communication over a 2-fiber duplex LC optical multi-mode fiber. Reversely, on the receiver side, the module de-multiplexes 2 sets of optical input signal and converts them to 4 channels of electrical data. The receiver module outputs electrical signals are also voltage compatible with Common Mode Logic (CML) levels. Figure 1 shows the functional block diagram of this product.

A single +3.3V power supply is required to power up the module. Both power supply pins VccTx and VccRx are internally connected and should be applied concurrently. As per MSA specifications the module offers 7 low speed hardware control pins (including the 2-wire serial interface): ModSelL, SCL, SDA, ResetL, LPMode, ModPrsL and IntL.

Module Select (ModSelL) is an input pin. When held low by the host, the module responds to 2-wire serial communication commands. The ModSelL allows the use of multiple QSFP28 modules on a single 2-wire interface bus – individual ModSelL lines for each QSFP28 module must be used.

Serial Clock (SCL) and Serial Data (SDA) are required for the 2-wire serial bus communication interface and enable the host to access the QSFP28 memory map.

The ResetL pin enables a complete module reset, returning module settings to their default state, when a low level on the ResetL pin is held for longer than the minimum pulse length. During the execution of a reset the host shall disregard all status bits until the module indicates a completion of the reset interrupt. The module indicates this by posting an IntL (Interrupt) signal with the Data\_Not\_Ready bit negated in the memory map. Note that on power up (including hot insertion) the module should post this completion of reset interrupt without requiring a reset.

Low Power Mode (LPMode) pin is used to set the maximum power consumption for the module to protect hosts that are not capable of cooling higher power modules, should such modules be accidentally inserted.

Module Present (ModPrsL) is a signal local to the host board which, in the absence of a module, is normally pulled up to the host Vcc. When a module is inserted into the connector, it completes the path to ground through a resistor on the host board and asserts the signal. ModPrsL then indicates a module is present by setting ModPrsL to a “Low” state.

Interrupt (IntL) is an output pin. Low indicates a possible module operational fault or a status critical to the host system. The host identifies the source of the interrupt using the 2-wire serial interface. The IntL pin is an open collector output and must be pulled to the Host Vcc voltage on the Host board

## Transceiver Block Diagram

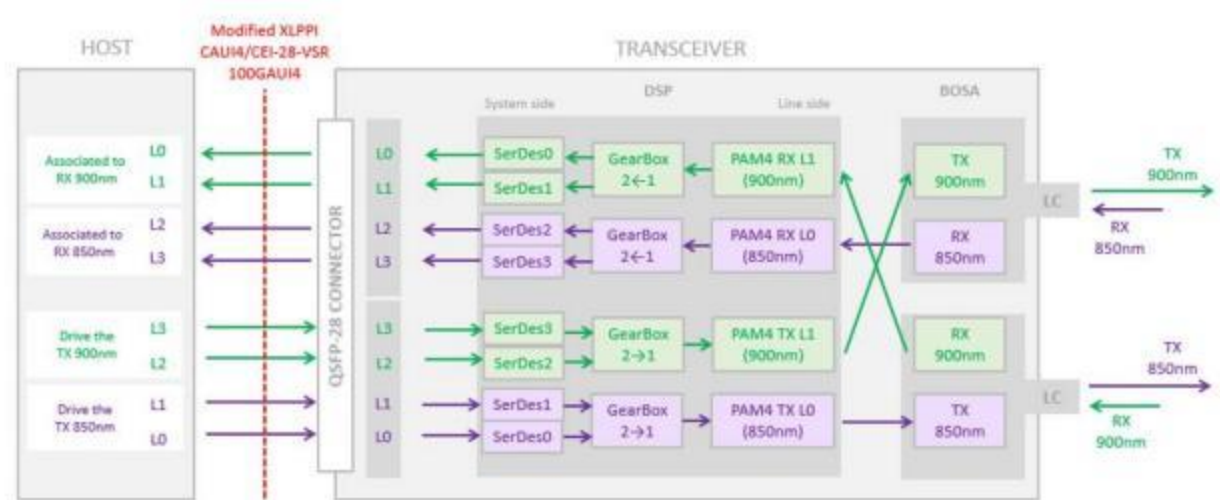

Figure 1. Transceiver Block Diagram

## Pin Assignment and Description

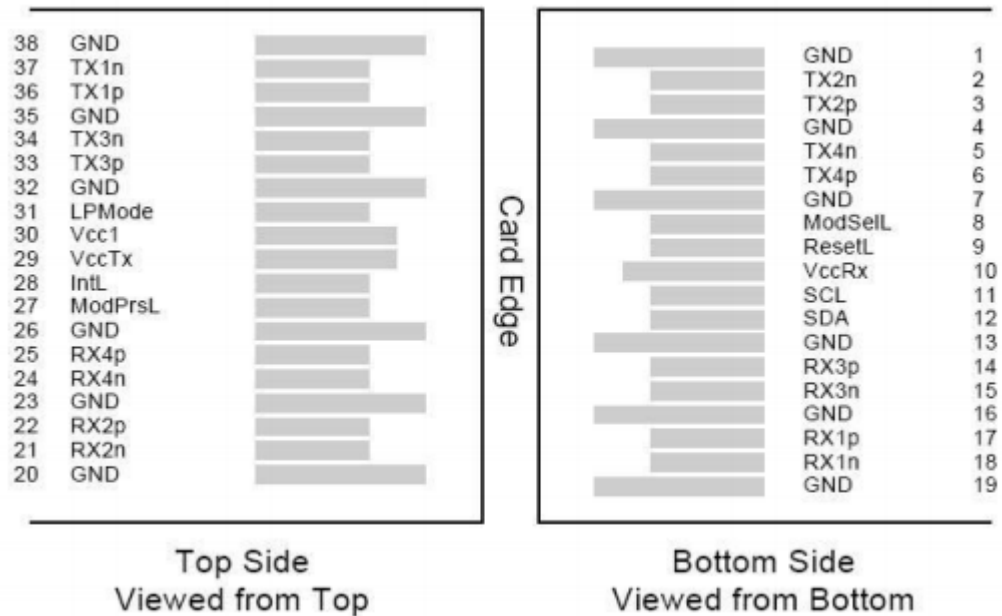

Figure 2. MSA Compliant Connector

**Pin Definition**

PIN	Logic	Symbol	Name/ Description	Notes
1		GND	Ground	1
2	CML-I	Tx2n	Transmitter Inverted Data Input	
3	CML-I	Tx2p	Transmitter Non- Inverted Data output	
4		GND	Ground	1
5	CML-I	Tx4n	Transmitter Inverted Data Input	
6	CML-I	Tx4p	Transmitter Non- Inverted Data output	
7		GND	Ground	1
8	LVTLL-I	ModSelL	Module Select	
9	LVTLL-I	ResetL	Module Reset	
10		VccRx	+3.3V Power Supply Receiver	2
11	LVC MOS-I/O	SCL	2-Wire Serial Interface Clock	
12	LVC MOS-I/O	SDA	2-Wire Serial Interface Data	
13		GND	Ground	
14	CML-O	Rx3p	Receiver Non- Inverted Data Output	
15	CML-O	Rx3n	Receiver Inverted Data Output	
16		GND	Ground	1
17	CML-O	Rx1p	Receiver Non- Inverted Data Output	
18	CML-O	Rx1n	Receiver Inverted Data Output	
19		GND	Ground	1
20		GND	Ground	1
21	CML-O	Rx2n	Receiver Inverted Data Output	
22	CML-O	Rx2p	Receiver Non- Inverted Data Output	
23		GND	Ground	1
24	CML-O	Rx4n	Receiver Inverted Data Output	1
25	CML-O	Rx4p	Receiver Non- Inverted Data Output	
26		GND	Ground	1
27	LVTTL-O	ModPrsL	Module Present	
28	LVTTL-O	IntL	Interrupt	
29		VccTx	+3.3 V Power Supply transmitter	2
30		Vcc1	+3.3 V Power Supply	2
31	LVTTL-I	LPMODE	Low Power Mode	

32		GND	Ground	1
33	CML-I	Tx3p	Transmitter Non-Inverted Data Input	
34	CML-I	Tx3n	Transmitter Inverted Data Output	
35		GND	Ground	1
36	CML-I	Tx1p	Transmitter Non-Inverted Data Input	
37	CML-I	Tx1n	Transmitter Inverted Data Output	
38		GND	Ground	1

Notes:

1. GND is the symbol for signal and supply (power) common for QSFP28 modules. All are common within the QSFP28 module and all module voltages are referenced to this potential unless otherwise noted. Connect these directly to the host board signal common ground plane.
2. VccRx, Vcc1 and VccTx are the receiver and transmitter power suppliers and shall be applied concurrently. Recommended host board power supply filtering is shown in Figure 4 below. Vcc Rx, Vcc1 and Vcc Tx may be internally connected within the QSFP28 transceiver module in any combination. The connector pins are each rated for a maximum current of 1000mA.

### Absolute Maximum Ratings

Parameter	Symbol	Min	Max	Unit
Storage Temperature	<i>T<sub>s</sub></i>	-40	+85	°C
Operating Case Temp (Standard)	TOP	10	70	°C
Operating Case Temp (Industrial)	TOP	-40	85	°C
Power Supply Voltage	Vcc	-0.5	3.6	V
Relative Humidity (non-cond.)	RH	0	85	%
Damage Threshold, each lane	THd	5		dBm

### Recommended Operating Conditions

Parameter	Symbol	Min	Typ	Max	Unit	Note
Operating Case Temp	<i>TOP</i>	10		70	°C	
Power Supply Voltage	Vcc	3.135	3.3	3.465	V	

Data Rate Accuracy		-100		100	ppm	
Pre-FEC Bit Error Rate				$2.4 \times 10^{-4}$		
Post-FEC Bit Error Rate				$1 \times 10^{-12}$		1
Control Input Voltage (High)		2		Vcc	V	
Control Input Voltage (Low)		0		0.8	V	
Link Distance	OM3 D1			70	m	2
	OM4 D2			100	m	2
	OM5 D3			150	m	2

Notes:

1. FEC provided by host system.
2. FEC required on host system to support maximum distance.

### Recommended Power Supply Filter

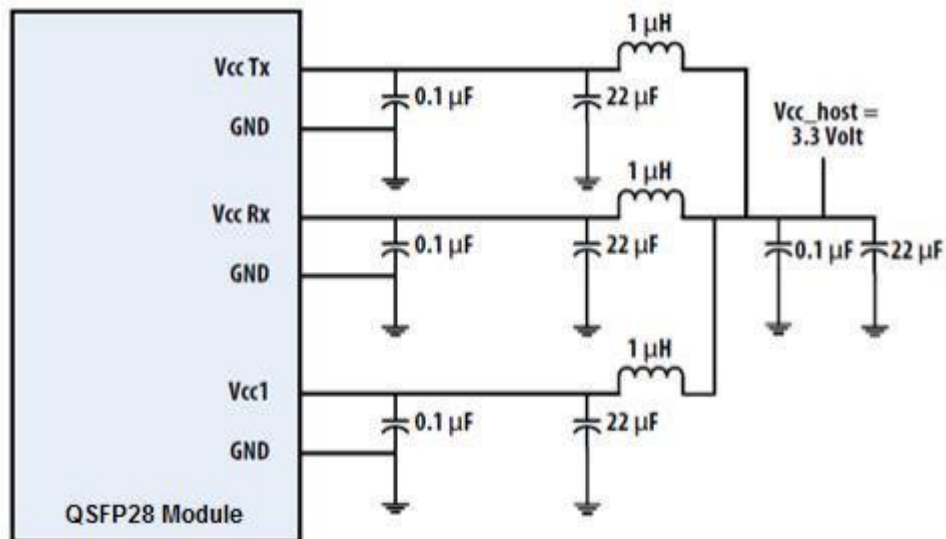

## Electrical Characteristics

Parameter	Symbol	Min	Typ	Max	Unit
Power Consumption				4	W
Supply Current	<i>I<sub>cc</sub></i>			1.21	A

## Electrical Characteristics-Transmitter (each lane)

Parameter	Symbol	Min	Typ	Max	Unit	Notes
Overload Differential Voltage pk-pk	TP1 a	900			mV	
Common Mode Voltage (V <sub>cm</sub> )	TP1	-350		2850	mV	1
Differential Termination Resistance Mismatch	TP1			10	%	At 1MHz
Differential Return Loss (SDD11)	TP1			See CEI-28G-VSR Equ. 13-19	dB	
Common Mode to Differential conversion and Differential to Common Mode conversion (SDC11, SCD11)	TP1			See CEI-28G-VSR Equation 13-20	dB	
Stressed Input Test	TP1 a	See CEI-28G-VSR Section 13.3.11.2.1				

## Electrical Characteristics-Receiver (each lane)

Parameter	Symbol	Min	Typ	Max	Unit	Notes
Differential Voltage, pk-pk	TP4			900	mV	
Common Mode Voltage (V <sub>cm</sub> )	TP4	-350		2850	mV	1
Common Mode Noise, RMS	TP4			17.5	mV	
Differential Termination Resistance Mismatch	TP4			10	%	At 1MHz

Differential Return Loss (SDD22)	TP4			See CEI-28G-VSR Equation 13-19	dB	
Common Mode to Differential conversion and Differential to Common Mode conversion (SDC22, SCD22)	TP4			See CEI-28G-VSR Equation 13-21	dB	
Common Mode Return Loss (SCC22)	TP4			-2	dB	2
Transition Time, 20 to 80%	TP4	9.5			ps	
Vertical Eye Closure (VEC)	TP4			5.5	dB	
Eye Width at 10-15 probability (EW15)	TP4	0.57			UI	
Eye Height at 10-15 probability (EH15)	TP4	228			mV	

Notes:

1. Vcm is generated by the host. Specification includes effects of ground offset voltage.
2. From 250MHz to 30GHz.

### Optical Characteristics-Transmitter

Parameter	Symbol	Min	Typ	Max	Unit	Notes
Center Wavelength Line0	$\lambda_c$	844		863	nm	
Center Wavelength Line1	$\lambda_c$	900		918	nm	
RMS Spectral Width	$\Delta\lambda_{rms}$			$\lambda_1$ : 0.6 $\lambda_2$ : 0.65	nm	
Average Launch Power, each Lane	PAVG	-6.2		4	dBm	
Optical Modulation Amplitude (OMA), each Lane	POMA	-4.2		3	dBm	1
Peak Power, each lane				-	dBm	
Launch power in OMA minus TDP, each lane		-5.6			dBm	



TDECQ, each lane				4.5	dB	
Extinction Ratio	ER	3.0			dB	
Transmitter transition time, each lane (max)				31	ps	
RIN12 OMA				-128	dB/Hz	
Optical Return Loss Tolerance	TOL			12	dB	
Average Launch	Poff			-30	dBm	
Power OFF Transmitter, each Lane						
Encircled Flux			$\geq 86\%$ at 19 $\mu\text{m}$ $\leq 30\%$ at 4.5 $\mu\text{m}$			2
Signaling rate, each lane			26.5625 $\pm$ 100ppm		Gbd/s	

### Optical Characteristics-Receiver

Parameter	Symbol	Min	Typ	Max	Unit	Notes
Center Wavelength Lane0	$\lambda_c$	844	850	863	nm	
Center Wavelength Lane1	$\lambda_c$	900	910	918	nm	
Damage Threshold, each Lane	THd	5			dBm	3
Average Receive Power, each lane		-8.2			dBm	4
Average power at receiver input, each lane (overload)				4	dBm	
Receiver Reflectance	RR			-12	dB	
Stressed receiver sensitivity in OMA, Lane2				-3.5	dBm	5
Receiver sensitivity(OMA outer), each lane				Max (-6.6, SECQ - 8) as per IEEE cl 150	dBm	
LOS Assert	LOSA	-30		-14.2	dBm	
LOS Deassert	LOSD			-11.2	dBm	
LOS Hysteresis	LOSH	0.5			dB	

Notes:

1. Even if the mTDEC<0.9 dB, the OMA (min) must exceed this value.
2. If measured into type A1a.2 50um fiber in accordance with IEC 61280-1-4.
3. The receiver shall be able to tolerate, without damage, continuous exposure to a modulated optical input signal having this power level on one lane. The receiver does not have to operate correctly at this input power.
4. Average receive power, each lane (min) is informative and not the principal indicator of signal strength. A received power below this value cannot be compliant; however, a value above this does not ensure compliance.
5. Measured with conformance test signal at TP3 as per following:

Stressed eye closure (SECq), each lane	4.5	dB
OMA of each aggressor, each lane	3	dBm

### Digital Diagnostic Functions

The following digital diagnostic characteristics are defined over the normal operating conditions unless otherwise specified.

Parameter	Symbol	Min	Typ	Max	Unit	Notes
Temperature monitor absolute error	<i>DMI TEMP</i>	-3		3	deg. C	Over operating temperature range
Supply voltage monitor absolute error	<i>DMI VCC</i>	-0.15		0.15	V	Over Full operating range
Channel RX power monitor absolute error	<i>DMIRX_CH</i>	-2		2	dB	1
Channel Bias current monitor	<i>DMIIbias_CH</i>	-10%		10%	mA	
Channel TX power monitor absolute error	<i>DMITX_CH</i>	-2		2	dB	1

Notes:

1. Due to measurement accuracy of different single mode fibers, there could be an additional +/-1 dB fluctuation, or a +/- 3 dB total accuracy.

## Mechanical Dimensions

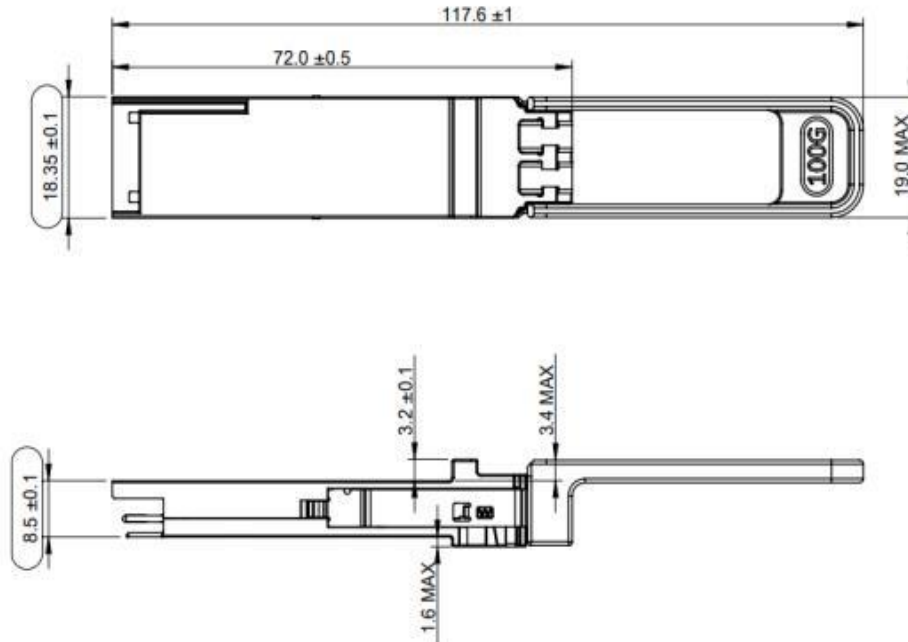

Figure 5. Mechanical Outline

## ESD

This transceiver is specified as ESD threshold 1kV for high-speed data pins and 2kV for all others electrical input pins, tested per MIL-STD-883, Method 3015.4 /JESD22- A114-A (HBM). However, normal ESD precautions are still required during the handling of this module. This transceiver is shipped in ESD protective packaging. It should be removed from the packaging and handled only in an ESD protected environment.

## Laser Safety

This is a Class 1M Laser Product according to EN 60825-1:2014. This product complies with 21 CFR 1040.10 except for deviations pursuant to Laser Notice No. 50, dated (June 24, 2007).

## Licensing

The following U.S. patents are licensed by Finisar to FluxLight, Inc.: U.S. Patent Nos: 7,184,668, 7,079,775, 6,957,021, 7,058,310, 6,952,531, 7,162,160, 7,050,720