

Rukus Compatible 100G-QSFP28-LR4-20KM-FL Quick Spec:

Part Number:	100G-QSFP28-LR4-20KM-FL 100G-QSFP28-LR4-20KM-EXT-FL 100G-QSFP28-LR4-20KM-IND-FL
Form Factor:	QSFP28
TX Wavelength:	1295/1300/1304/1309nm
Reach:	20km
Cable Type:	SMF
Rate Category:	100GBase
Interface Type:	LR4
DDM:	Yes
Connector Type:	Dual-LC



Rukus Compatible 100G-QSFP28-LR4-20KM-FL Features

- Hot pluggable QSFP28 MSA form factor
- Compliant to IEEE 802.3ba 100GBASE-LR4
- Supports 103.1Gb/s aggregate bit rate
- Up to 20km reach for G.652 SMF
- Single +3.3V power supply
- Transmitter: cooled 4x25Gb/s LAN WDM DFB
- Receiver: 4x25Gb/s PIN
- Chip On Board Package Component
- 4x25G Electrical Interface (OIF CEI-28G-VSR)
- Maximum power consumption 4.0W
- Duplex LC receptacle
- RoHS-6 compliant
- Operating Case Temperature
 - Standard: 0°C to +70 °C
 - Extended -5°C to +85 °C
 - Industrial -40°C to +85 °C

Rukus Compatible 100G-QSFP28-LR4-20KM-FL Applications

- 100G-LR4 Ethernet
- Datacenter Enterprise networking

Rukus Compatible 100G-QSFP28-LR4-20KM-FL General Description

The FluxLight 100G-QSFP28-LR4-20KM is a 100Gb/s transceiver module designed for optical communication applications compliant to 100GBASE-LR4 of the IEEE 802.3ba standard. The module converts 4 input channels of 25Gb/s electrical data to 4 channels of LAN WDM optical signals and then multiplexes them into a single channel for 100Gb/s optical transmission. Reversely on the receiver side, the module de-multiplexes a 100Gb/s optical input into 4 channels of LAN WDM optical signals and then converts them to 4 output channels of electrical data.

The central wavelengths of the 4 LAN WDM channels are 1295.56, 1300.05, 1304.58 and 1309.14 nm as members of the LAN WDM wavelength grid defined in IEEE 802.3ba. The high-performance cooled LAN WDM DFB transmitters and high sensitivity PIN receivers provide superior performance for 100Gigabit Ethernet applications up to 20km links and compliant to optical interface with 100GBASE-LR4 requirements specified in IEEE 802.3ba Clause 88.

Absolute Maximum Rating

The operation in excess of any absolute maximum ratings might cause permanent damage to this module.

Parameter	Symbol	Min	Max	Unit	Notes
Storage Temperature	TS	-40	+85	degC	
Operating Case Temperature	TOP	0	70	degC	
Power Supply Voltage	VCC	-0.5	3.6	V	
Relative Humidity	RH	0	85	%	non-condensation
Damage Threshold, each Lane	THd	5.5		dBm	

Recommended Operating Conditions

Parameter	Symbol	Min	Typical	Max	Unit	Notes
Operating Case Temperature	TC	0		+70	degC	
Data Rate Accuracy		-100		+100	ppm	
Control Input Voltage High			2	Vcc	V	
Control Input Voltage Low		0.8			V	
Link Distance with G.652				20	km	

Electrical Characteristics

The following electrical characteristics are defined over the Recommended Operating Environment unless otherwise specified

Parameter	Symbol	Min	Typical	Max	Unit	Notes
Supply Voltage	Vcc	3.135		3.465	V	
Supply Current	Icc			1.15	A	
Module total power	P			4	W	

Optical Characteristics

Parameter	Symbol	Min	Typical	Max	Unit	Notes
Wavelength Assignment	L0	1294.53	1295.56	1296.59	nm	
	L1	1299.02	1300.05	1301.09	nm	
	L2	1303.54	1304.58	1305.63	nm	
	L3	1308.09	1309.14	1310.19	nm	
Transmitter						
Side Mode Suppression Ratio	SMSR	30			dB	1
Total Average Launch Power	PT			10.5	dBm	
Average Launch Power, each Lane	PAVG	-4.3		4.5	dBm	
Extinction Ratio	ER	4			dB	

Average Launch Power OFF Transmitter, each Lane	Poff			-30	dBm	
Receiver						
Damage Threshold, each Lane	THd	5.5			dBm	
Average Receive Power, each Lane		-10.6		4.5	dBm	
Receiver Sensitivity, each Lane(OMA)	SEN	-8.6		4.5	dBm	
Receiver Reflectance	RR			-26	dB	
LOS Assert	LOSA	-24			dBm	
LOS Deassert	LOSD			-11.6	dBm	
LOS Hysteresis	LOSH	0.5			dB	

Recommended Power Supply Filter

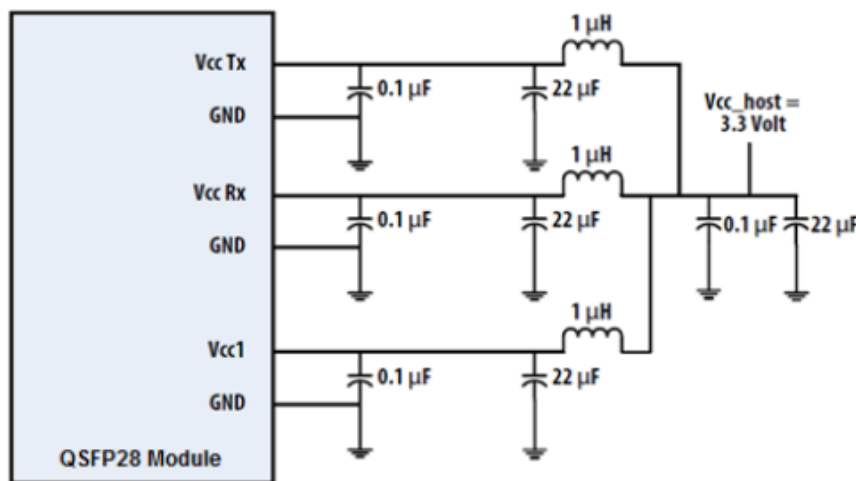

Figure 3. Recommended Power Supply Filter

Digital Diagnostic Functions

The following digital diagnostic characteristics are defined over the normal operating conditions unless otherwise specified.

Parameter	Symbol	Min	Max	Unit	Notes
Temperature monitor absolute error	DMI_Temp	-5	5	°C	
Supply voltage monitor absolute error	DMI_VCC	-0.1	0.1	V	
Channel RX power monitor absolute error	DMI_RX_Ch	-3	3	dB	
Channel Bias current monitor	DMI_Ibias_Ch	-10%	10%	mA	
Channel TX power monitor absolute error	DMI_TX_Ch	-3	3	dB	

Mechanical Dimensions

Units: mm

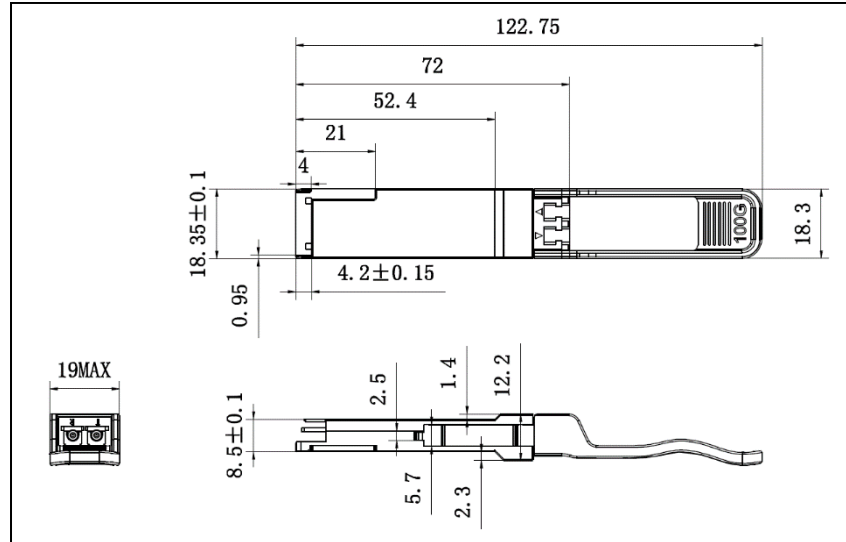

Pin Assignment and Description



Pin Assignment

Pin	Logic	Symbol	Description	Plug Sequence
1		GND	Ground	1
2	CML-I	Tx2n	Transmitter Inverted Data Input	3
3	CML-I	Tx2p	Transmitter Non-Inverted Data Input	3
4		GND	Ground	1
5	CML-I	Tx4n	Transmitter Inverted Data Input	3
6	CML-I	Tx4p	Transmitter Non-Inverted Data Input	3
7		GND	Ground	1
8	LVTTL-I	ModSelL	Module Select	3
9	LVTTL-I	ResetL	Module Reset	3
10		Vcc Rx	+3.3V Power Supply Receiver	2
11	LVC MOS-I/O	SCL	2-wire serial interface clock	3
12	LVC MOS-I/O	SDA	2-wire serial interface data	3
13		GND	Ground	1
14	CML-O	Rx3p	Receiver Non-Inverted Data Output	3
15	CML-O	Rx3n	Receiver Inverted Data Output	3
16		GND	Ground	1
17	CML-O	Rx1p	Receiver Non-Inverted Data Output	3
18	CML-O	Rx1n	Receiver Inverted Data Output	3
19		GND	Ground	1
20		GND	Ground	1
21	CML-O	Rx2n	Receiver Inverted Data Output	3
22	CML-O	Rx2p	Receiver Non-Inverted Data Output	3
23		GND	Ground	1
24	CML-O	Rx4n	Receiver Inverted Data Output	3
25	CML-O	Rx4p	Receiver Non-Inverted Data Output	3
26		GND	Ground	1
27	LVTTL-O	ModPrsL	Module Present	3
28	LVTTL-O	IntL	Interrupt	3
29		Vcc Tx	+3.3V Power supply transmitter	2
30		Vcc1	+3.3V Power supply	2
31	LVTTL-I	LPMode	Low Power Mode	3
32		GND	Ground	1
33	CML-I	Tx3p	Transmitter Non-Inverted Data Input	3
34	CML-I	Tx3n	Transmitter Inverted Data Input	3
35		GND	Ground	1
36	CML-I	Tx1p	Transmitter Non-Inverted Data Input	3
37	CML-I	Tx1n	Transmitter Inverted Data Input	3
38		GND	Ground	1

RoHS Compliance

FluxLight is fully committed to environment protection and sustainable development and has set in place a comprehensive program for removing polluting and hazardous substances from all of its products. The relevant evidence of RoHS compliance is held as part of our controlled documentation for each of our compliant products. RoHS compliance parts are available to order, please refer to the ordering information section for further details.

ESD

This transceiver is specified as ESD threshold 1kV for SFI pins and 2kV for all other electrical input pins, tested per MIL-STD-883, Method 3015.4 /JESD22-A114-A (HBM). However, normal ESD precautions are still required during the handling of this module. This transceiver is shipped in ESD protective packaging. It should be removed from the packaging and handled only in an ESD protected environment.

Laser Safety

This is a Class 1 Laser Product according to EN 60825-1:2014. This product complies with 21 CFR 1040.10 and 1040.11 except for deviations pursuant to Laser Notice No. 50, dated (June 24, 2007).

Caution: Use of controls or adjustments or performance of procedures other than those specified herein may result in hazardous radiation exposure.

Licensing

The following U.S. patents are licensed by Rukus to FluxLight, Inc.:

U.S. Patent Nos: 7,184,668, 7,079,775, 6,957,021, 7,058,310, 6,952,531, 7,162,160, 7,050,720